

SERVICE MANUAL

VIDEO MONITOR



SANYO

VM4509

(EUROPE)

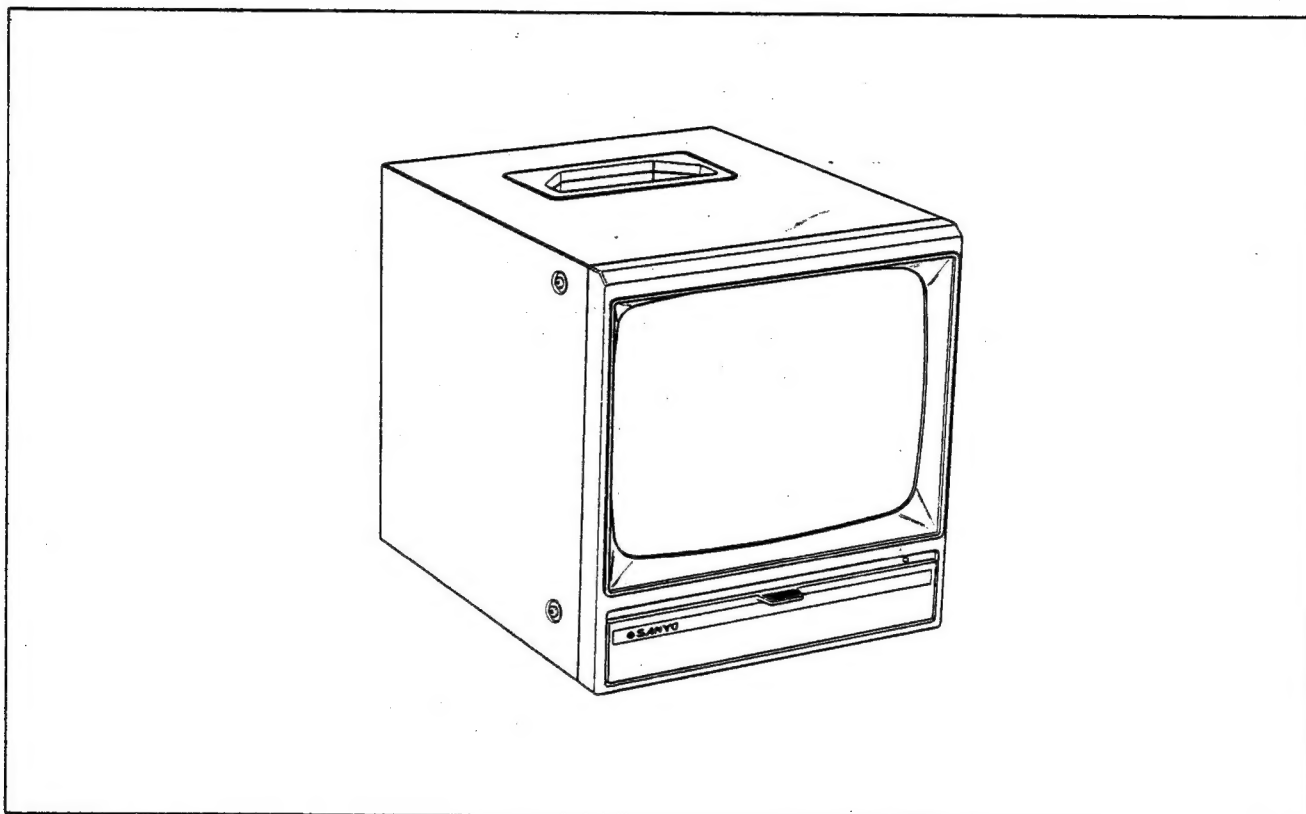









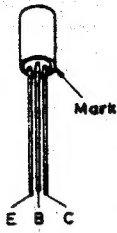

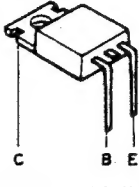

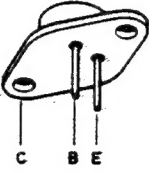

SPECIFICATIONS

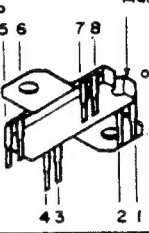
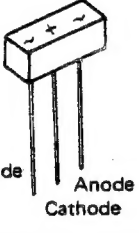
Scanning system	625 lines, 30 frame per sec.
Power source	AC 220 V 50 Hz, DC 12 V
Power consumption	AC 32 W, DC 17 W
Picture tube	10-inch diagonal, 90° deflection 240XB4A or 240YB4
Semiconductors	Transistor 13 Diode 16
Horizontal resolution	more than 750 lines ave. (center)
Cabinet dimension	220mm (W) x 238mm (H) x 266mm (D) approx.
Net weight	5.8 kg approx.
Video	
input signal level	1.0 Vp-p
input impedance	High - 75 ohm switchable
output signal level	0.5 - 1.5 Vp-p
output impedance	over 10K ohm

NOTE: Specifications are subject to change without notice.

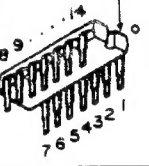
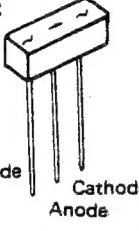
TERMINAL VIEW

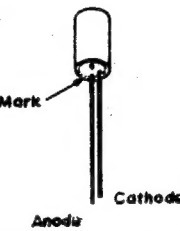
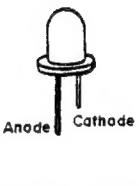
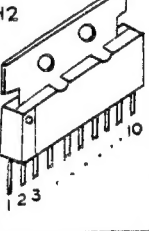
<p>2SA201 2SB187</p> 	<p>2SA495</p> 	<p>2SA608 2SA643 2SA659 2SA733 2SB598 2SC536 2SC929 2SC930 2SC945 2SC1175 2SC1293 2SC2271 2SC2228 2SD400 2SD438</p> 	<p>2SD314 2SD331</p> 	<p>2SD613 2SB507 2SB511 2SC1096 2SC1506 2SC1507 2SC1520 2SC1755 2SC1756 2SC2373 2SD823 2SD313 2SD325 2SD386</p> 
<p>2SC983 2SC1941</p> 	<p>2SD612</p> 	<p>2SB375 2SB407 2SB474 2SC1024 2SC1025 2SC1046 2SC1050 2SC1295 2SC1875 2SD24 2SD315 2SD353 2SD575 2SD627</p> <p>2SC1892</p> 	<p>2SC2057</p> 	<p>LA4030P</p> 
<p>S2VC10</p> 	<p>1JZ61 1R5TH61 ERB30-15 ERC27-13 V09G</p> 	<p>1S188 1S1834 1S2076 ERB-24-02D ERB-24-04D ERB-24-06D SM-1-02FR SM-1-04FR SM-1.5-02FRT WZ-063 WZ-075 WZ-110 RD-6.2E RD-7.5E</p> <p>SIB01-02</p> 	<p>LA1354 μPC596C</p> 	<p>LA1352 CA3065 LA1201 LA1363 LA1365 SN76666 μPC595C</p> 
<p>S2VC10R</p> 	<p>DS-113</p> 	<p>SV-31</p> 	<p>SLP-131B</p> 	<p>LA1385 μPC1031H2</p> 

E : Emitter C : Collector B : Base S : Shield

CONTROLS AND TERMINAL IDENTIFICATION

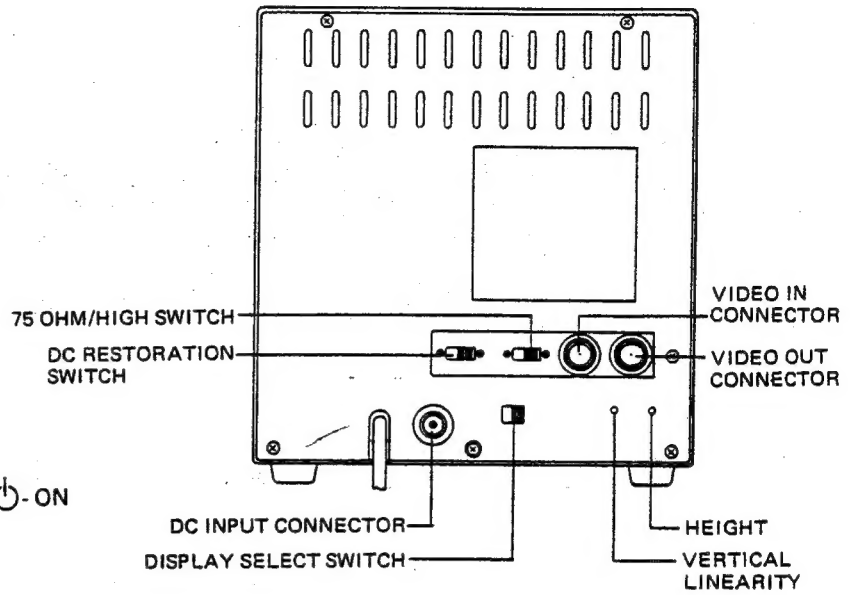
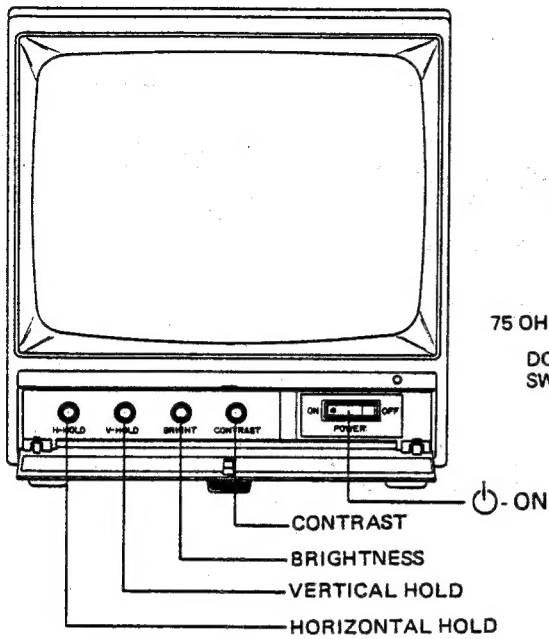

MECHANICAL DISASSEMBLIES

CABINET BACK REMOVAL

1. Carefully lay cabinet face down on soft mat.
2. Remove five(5) screws securing the cabinet back.
(See Fig. 1)

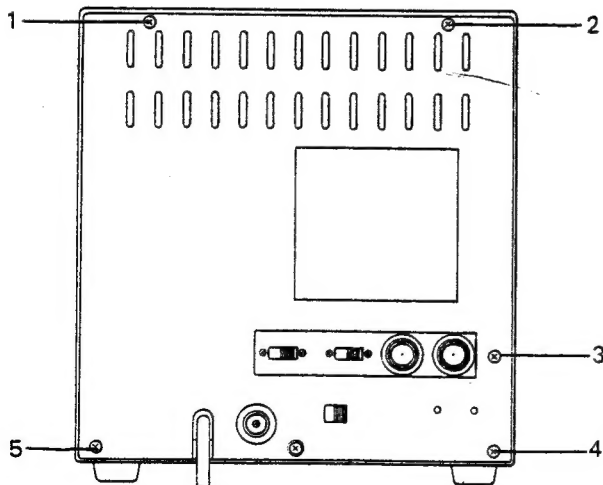

Fig. 1

CHASSIS REMOVAL

1. First remove the cabinet back and remove four(6 - 9) screws securing the cabinet. (See Fig. 2)
2. Disconnect anode cap, picture tube socket, grounding connector, and LED connector. Then slightly loosen the screw securing the deflection yoke.
3. Remove six(10 - 15) screws. Separate chassis from the escutcheon. (See Fig. 2)

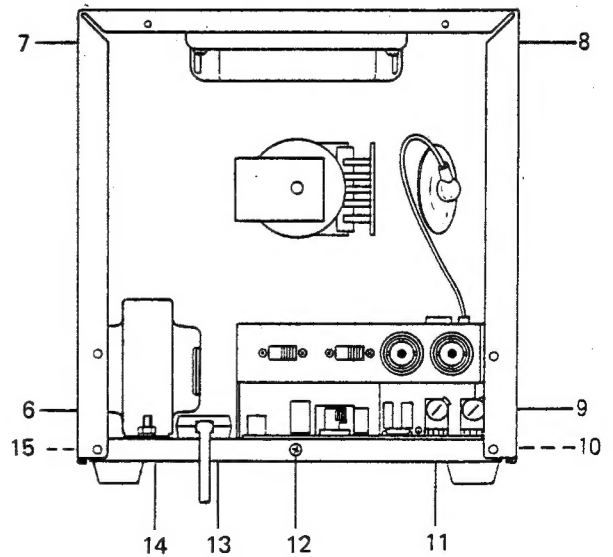

Fig. 2

IMPORTANT NOTICE FOR SERVICE PERSONNEL BEFORE SERVICING

PLEASE READ BEFORE ATTEMPTING SERVICE

1. Line voltage must be kept within $\pm 10\%$ of the rated voltage.
2. When operating at line voltage, confirm the DC voltage at TP1 (J403) is $10.5 \pm 0.1V$. (Adjust VR701)
3. Keep line voltage when adjusting Horizontal Oscillator or Deflection circuit.
4. When adjusting Horizontal Oscillator Frequency, do not vary this frequency more than $\pm 800Hz$ from 15,625Hz center frequency (800Hz equals 16 bars).
5. DO NOT DISCHARGE, ARC, OR MEASURE HIGH VOLTAGE WHEN HIGH VOLTAGE LEAD IS CONNECTED TO CRT. DISCHARGE 2ND ANODE OF CRT ONLY AFTER HIGH VOLTAGE LEAD HAS BEEN DISCONNECTED. DO NOT DISCHARGE HIGH VOLTAGE LEAD AT ANY TIME, DAMAGE TO TRANSISTORS MAY RESULT.
6. While the receiver is in operation, do not attempt to connect or disconnect any wires.
7. Disconnect all power before attempting any repairs.
8. When the power is on, do not attempt to short any portion of the circuit. This shorting may cause damage to the transistors in the receiver.

ADJUSTMENT

PICTURE FOCUS

Adjust focus-VR (VR602) to obtain the best focus. While the adjustment, do not disconnect the picture tube coating earth.

PICTURE WIDTH

1. If picture is too wide, cut the link J605. This connection may have been opened in some chassis as a result of factory adjustment.
2. If picture is still too wide, cut the link J606. (See Fig. 3)

DEFLECTION YOKE AND CENTERING RINGS

1. Loosen the Deflection Yoke clamp and carefully move the yoke on the neck of the picture tube as far forward as possible. Rotate the yoke until the top and bottom edges of the raster are straight. Tighten the clamp.
2. Center the raster and eliminate shaded corners by rotating the centering rings until the best effect is obtained.

VERTICAL HEIGHT AND LINEARITY

PRELIMINARY

1. Adjust AC power to the rated voltage with a voltage regulator.
2. Set V-Hold (VR503), Height (VR502) and V-Linearity (VR501) controls to the mid-position and Contrast (VR201) Brightness (VR202) controls to the fully clockwise.
3. Turn the switch "ON" and leave the receiver for about 5 minutes before proceeding the following adjustments.

ADJUSTMENT PROCEDURE

1. Adjust the V-Linearity control to obtain the best linearity.
2. Adjust the Height control to obtain proper picture height.
3. Rotate V-Hold control completely clockwise or counterclockwise to confirm the picture rolls up or down at both extreme positions.

SUB-BRIGHTNESS

1. Set Brightness (VR202) and Contrast (VR201) controls to maximum.
2. Adjust Sub-Brightness control (VR203) to sufficient brightness.

PARTS LOCATION

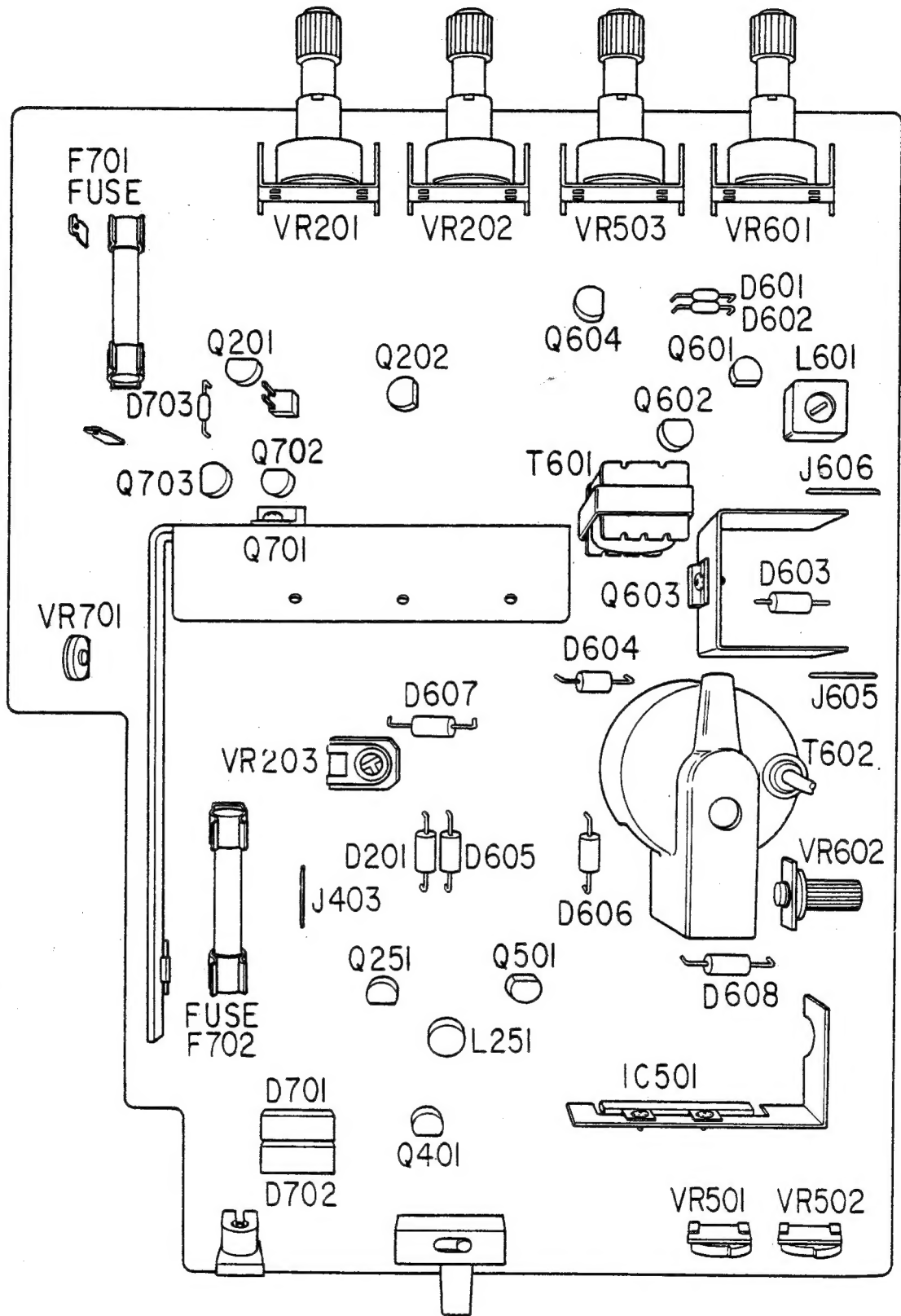
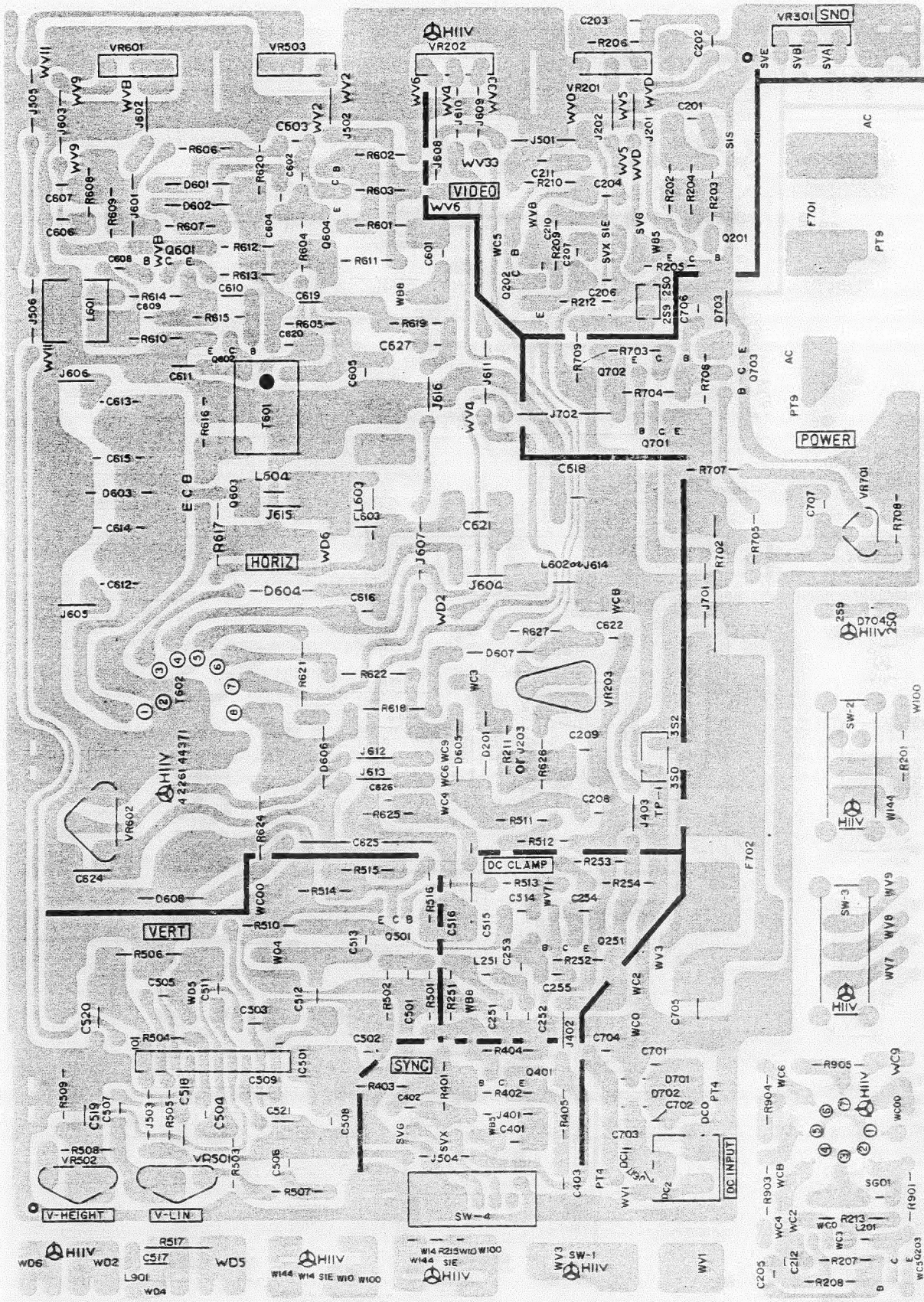
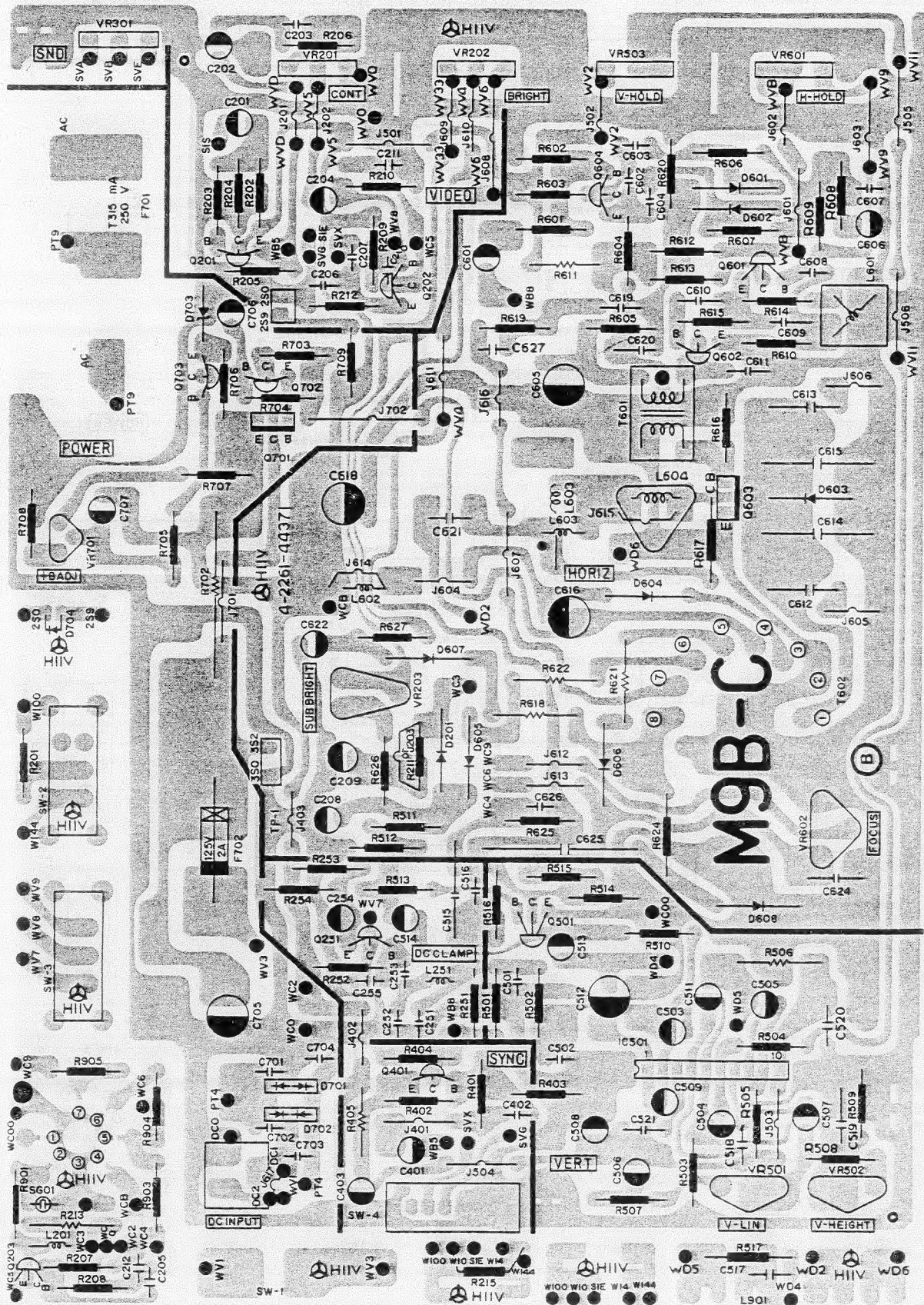

Fig. 3

CIRCUIT BOARD DIAGRAM



CIRCUIT BOARD DIAGRAM



SCHEMATIC DIAGRAM

NOTES:

1. All resistance values in ohm.
K=1,000 M=1,000,000
2. Unless otherwise noted in schematic diagram, all capacitors less than 1 are expressed in mfd and the values larger than 1 are in pF.
3. Voltage reading taken with High Impedance Voltmeter from point indicated to chassis ground, contrast at max., other controls at normal, local line voltage.

4. All waveforms measured with strong signal input, contrast set to give normal picture.
5. Voltage reading may vary $\pm 20\%$.
6. This is a fundamental circuit diagram. Some production changes may be made without revision of the diagram.

△: For SAFETY use only equivalent replacement part.

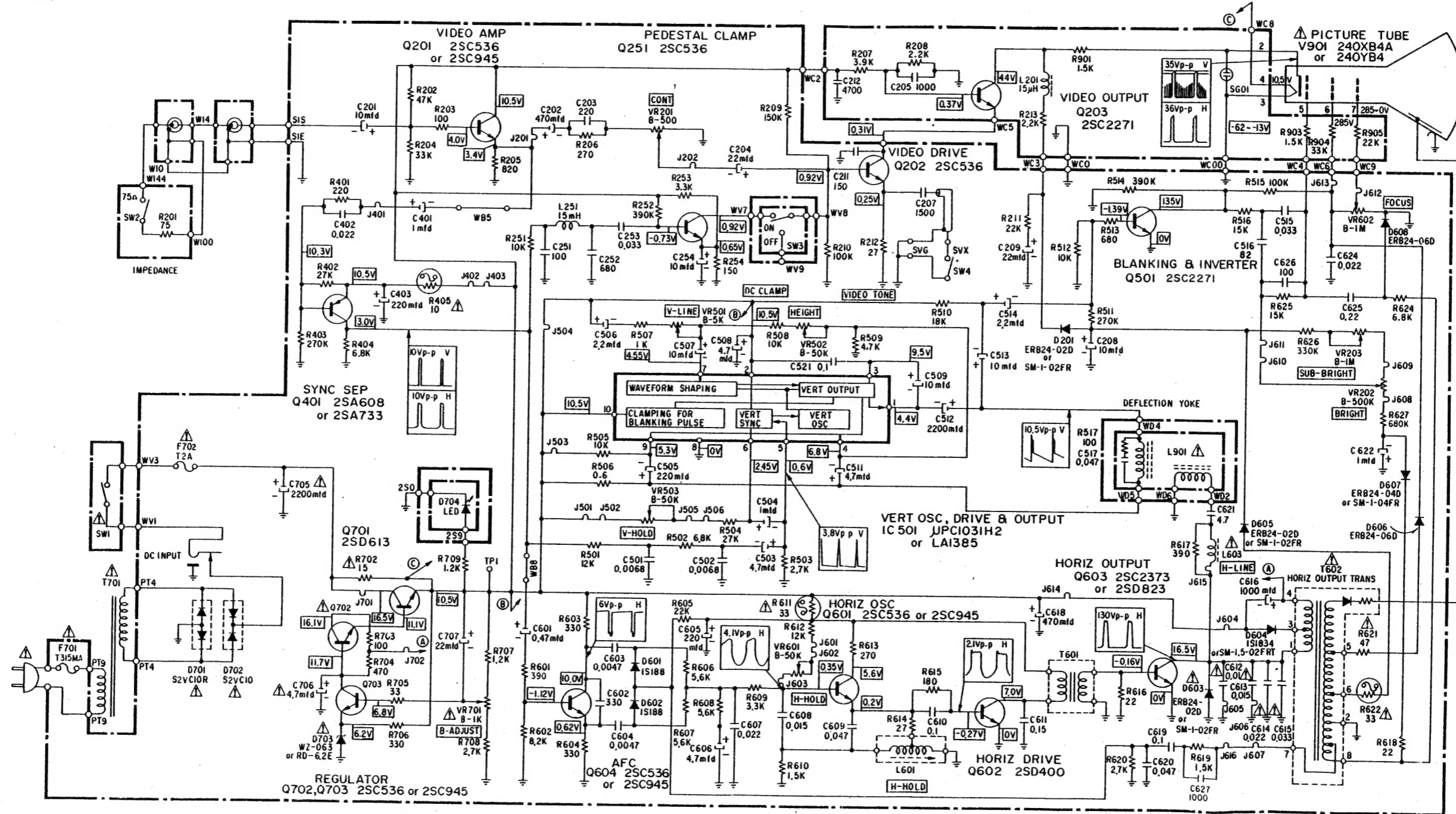

K-0102

MODIFICATION NOTICE



VIDEO MONITOR



Date: September 6, 1982

Wrong internal connections of High Voltage Transformer printed in the schematic diagram of the service manual were printed by mistake. Please refer to the schematic diagram printed in this modification notice for servicing of model VM4509.

SCHEMATIC DIAGRAM

NOTES:

1. All resistance values in ohm.
K=1,000 M=1,000,000
2. Unless otherwise noted in schematic diagram, all capacitors less than 1 are expressed in mfd and the values larger than 1 are in pF.
3. Voltage reading taken with High Impedance Voltmeter from point indicated to chassis ground, contrast at max., other controls at normal, local line voltage.

4. All waveforms measured with strong signal input, contrast set to give normal picture.
5. Voltage reading may vary $\pm 20\%$.
6. This is a fundamental circuit diagram. Some production changes may be made without revision of the diagram.

⚠: For SAFETY use only equivalent replacement part.

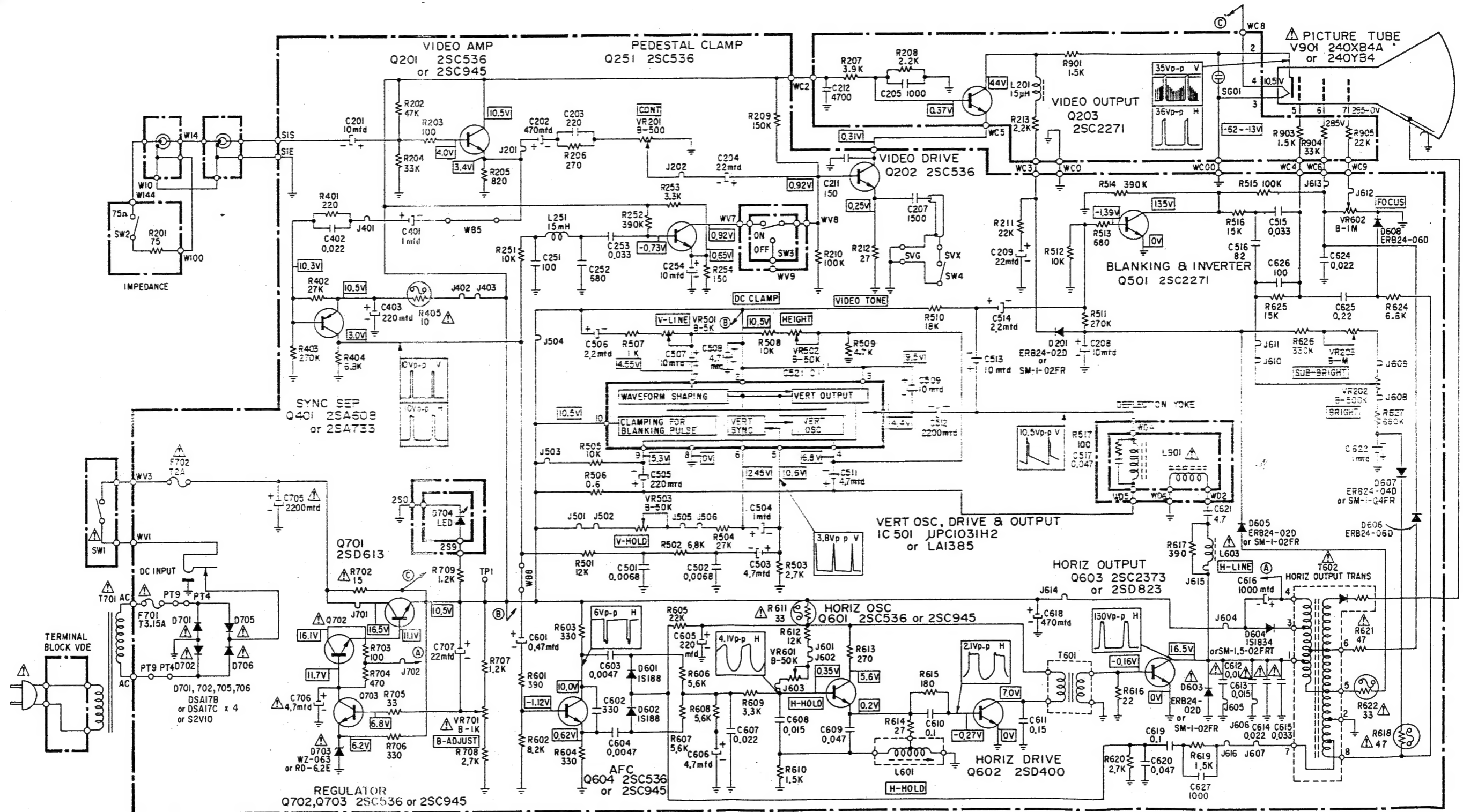

REPLACEMENT PARTS LIST

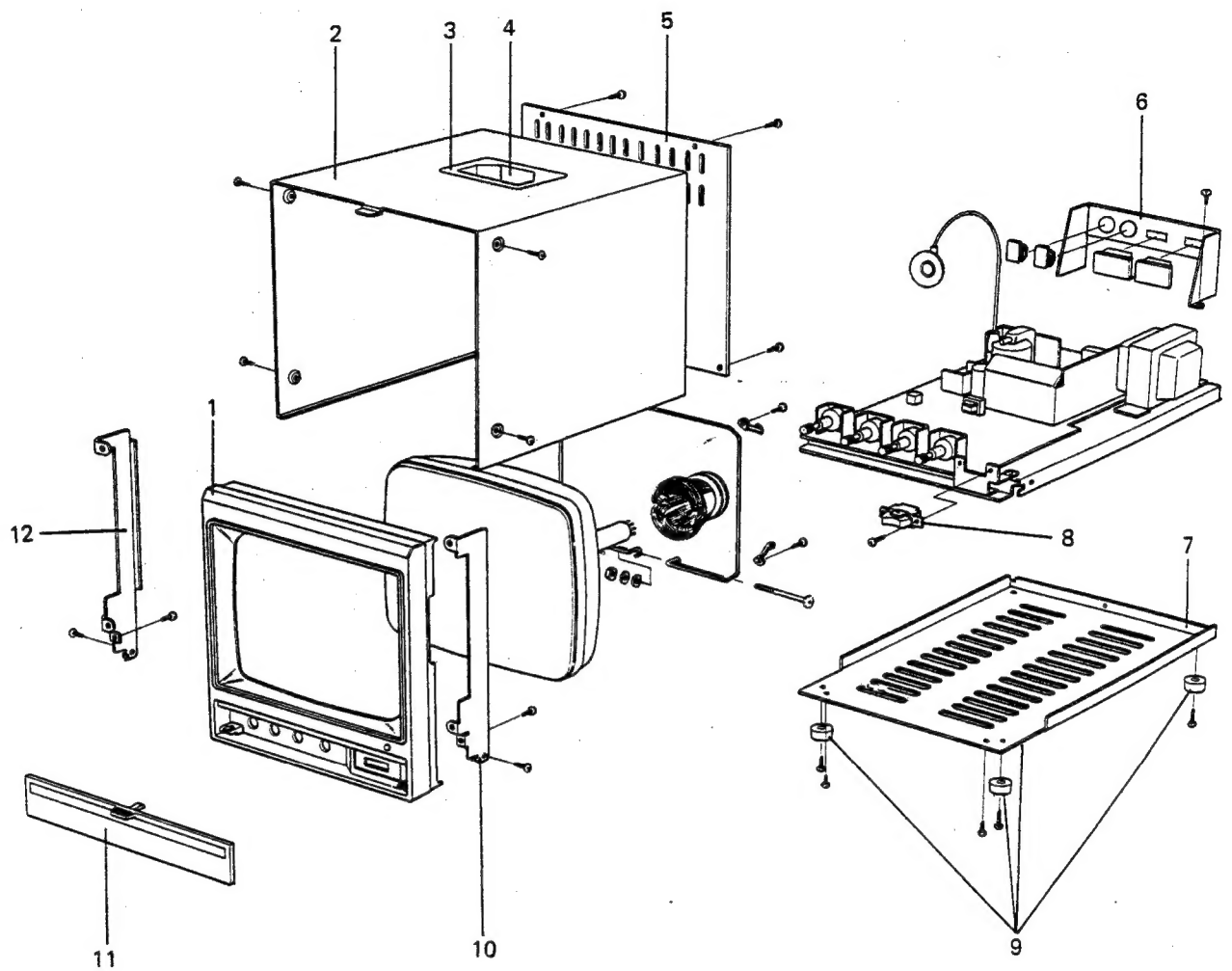

Key No.	Parts No.	Description	Q'ty
1	111 0 1211 08971	ESCUTCHEON ASSY-MAT	1
2	111 2 1111 12070	CABINET-MAT	1
3	111 2 1711 23571	HANDLE TOP-MAT	1
4	111 2 1711 23671	HANDLE BOTTOM-MAT	1
5	111 2 1171 26570	BACK COVER-MAT	1
6	111 2 3651 22070	CONNECTOR MTG BRKT-MAT	1
7	111 2 1181 12770	BOTTOM COVER-MAT	1
8	4 2311 05272	SEESAW SWITCH	1
9	111 2 1731 11270	FEET-MAT	4
10	111 2 3311 23170	RIGHT CHASSIS MTG BRKT-MAT	1
11	111 0 1371 04871	DOOR ASSY-MAT-B	1
12	111 2 3311 23270	LEFT CHASSIS MTG BRKT-MAT	1

PARTS LIST

Schematic Location	Parts No.	Description	Q'ty	Schematic Location	Parts No.	Description	Q'ty	
CHASSIS PARTS				VARIABLE RESISTORS				
111 0	6211 06070	POWER RAD PL AY-MAT	1	VR201	4 2221 35670	16FRN25ZB-500PK	1	
111 2	3121 18770	CHASSIS FRAME-MAT	1	VR202	4 2221 35870	16FRN25ZB-500PKP	1	
111 2	3651 22070	CONN MTG BRKT-MAT	1	VR203	4 2221 34770	9C2VFRB-1M	1	
111 2	3691 16570	SW MTG BRKT-MAT	1	VR501	4 2221 35470	12CFR4B-5K	1	
111 2	5291 12870	FBT HOLD BRKT-MAT	1	VR502	4 2221 35570	12CFR4B-50K	1	
111 2	6211 22670	HOR RAD PLATE-TJJ	1	VR503	4 2221 35770	16FRN25ZB-50KPK	1	
111 2	6211 22770	VERT RAD PLATE-TJJ	1	VR601	4 2221 35770	16FRN25ZB-50KPK	1	
111 2	6221 14170	M CONN EARTH TIP-MAT	1	VR602	4 2221 35070	15CHF7B-1M	1	
111 2	7221 11570	CORD FIXER-MAF	1	Δ VR701	4 2221 29470	8PFRB-1K	1	
PACKING MATERIALS				CAPACITORS				
111 6	1421 59971	IND CORR CASE-MAT-B	1	C201	C1CRE-106A--	ELECT 10M 16V	1	
111 6	2511 20870	IND POLY COVER-MAT	1	C202	C1ARE-477A--	ELECT 470M 10V	1	
111 6	3111 55370	TOP INNER CUSH-MAT	1	C203	C1HYDK221W--	CERAMIC 220P W 50V	1	
111 6	3111 55470	BOT INNER CUSH-MAT	1	C204	C1ARE-226A--	ELECT 22M 10V	1	
111 6	3231 12170	PROTECT SHEET-MAT	1	C205	C1HYDK102W--	CERAMIC 1000P W 50V	1	
111 6	9541 20100	FLAT TAPE	Z	C207	C1HYDK152W--	CERAMIC 1500P W 50V	1	
ACCESSORIES AND LABELS				or				
111 6	2701 15001	PM ASSY-MAT-B	1	C208	C2ARE-106A--	ELECT 10M 100V	1	
111 6	2711 05870	ENVELOPE-SR-C	(1)	C209	C2ARE-226A--	ELECT 22M 100V	1	
111 6	4211 26469	SCHEMATIC DIAG-M9	(1)	C211	C1HCDK151SL-	CERAMIC 150P SL 50V	1	
111 6	4111 99571	INST MANUAL-MAT-B	(1)	C212	C1HYDP472Z--	CERAMIC 4700P Z 50V	1	
111 6	4551 16970	SERIAL NO LABEL	1	C251	C1HCDJ101SL-	CERAMIC 100P SL 50V	1	
111 6	4761 33070	SPEC LABEL MAT-D	1	C252	C1HYDK681W--	CERAMIC 680P W 50V	1	
SCREWS-CABINET				C501				
102 3	1903 01004	SBT 1. 3.0X 10. C2	4	C502	C1HFRK333A--	MYLAR 0.033M 50V	1	
102 3	2203 00802	SBT , 3.0X 8. Z1	7	C503	C1CRE-106A--	ELECT 10M 16V	1	
102 3	2203 01001	SBT , 3.0X 10. Z1	9	C401	C1HRE-105A--	ELECT 1M 50V	1	
102 3	2204 01202	SBT , 4.0X 12. Z1	9	C402	C1HFRK223A--	MYLAR 0.022M 50V	1	
SCREWS-CHASSIS				C403				
101 3	1102 60401	SNB , 2.6X 4. Z1	4	C501	C1HFRK682A--	MYLAR 0.0068M 50V	1	
101 3	1504 01201	STR , 4.0X 12. Z1	2	C502	C1HFRK682A--	MYLAR 0.0068M 50V	1	
102 3	2203 00601	SBT , 3.0X 6. Z1	2	C503	C1ERE-475A--	ELECT 4.7M 25V	1	
102 3	2203 00802	SBT , 3.0X 8. Z1	6	C504	C1ETDM105A--	TANTAL 1M 25V	1	
102 3	2203 01602	SBT , 3.0X 16. Z1	2	or	C1ETEM105A--	TANTAL 1M 25V	1	
102 3	2203 50801	SBT , 3.5X 8. Z1	2	C505	C1CRE-227A--	ELECT 220M 16V	1	
105 3	1204 00004	SBW , 4.0. RB	2	C506	C1HRE-225A--	ELECT 2.2M 50V	1	
111 3	1104 01014	SBW , 4.0X10.0X08Z1	2	C507	C1CRE-106A--	ELECT 10M 16V	1	
124 3	1104 00003	ZRN 1. 4.0.	2	C508	C1ERE-475A--	ELECT 4.7M 25V	1	
ELECTRICAL PARTS				C509				
L201	4 2531 04771	FILTER COIL	1	C511	C1CTDM475A--	TANTAL 4.7M 16V	1	
L251	4 2531 14270	FILTER COIL 15MH	1	or	C1CTEM475A--	TANTAL 4.7M 16V	1	
L601	4 2731 06170	HORIZ OSC COIL	1	C512	C1ARE-228A--	ELECT 2200M 10V	1	
Δ L603	4 2741 05370	LINEARITY COIL	1	C513	C1CRE-106A--	ELECT 10M 16V	1	
Δ L901	4 2761 50670	DEFLECTION YOKE	1	C514	C1HRE-225A--	ELECT 2.2M 50V	1	
T601	4 2731 06270	HORIZ DRIVE TRANS	1	C515	C2GQRK333A--	POLYPR 0.033M 400V	1	
Δ T602	4 2751 51300	FLYBACK TRANS	1	C516	C2HCDK820SL-	CERAMIC 82P SL 500V	1	
Δ T701	4 2511 43020	POWER TRANS	1	C517	C1HFRK473A--	MYLAR 0.047M 50V	1	
SMALL PARTS				C521				
Δ	4 2261 44371	PC BOARD M9B-C	1	C601	C1HRE-474A--	ELECT 0.47M 50V	1	
	4 2311 05272	SEESAW SWITCH	1	C602	C1HYDK331W--	CERAMIC 330P W 50V	1	
	4 2311 07470	SLIDE SWITCH	2	C603	C1HFRK472A--	MYLAR 0.0047M 50V	1	
	4 2311 09170	SLIDE SWITCH	1	C604	C1HFRK472A--	MYLAR 0.0047M 50V	1	
	4 2350 61600	TERMINAL SOCKET	1	C605	C1CRE-227A--	ELECT 220M 16V	1	
	4 2351 05470	CRT SOCKET	1	C606	C1ERE-475A--	ELECT 4.7M 25V	1	
	4 2351 45473	FUSE HOLDER	1	C607	C1HFRK223A--	MYLAR 0.022M 50V	1	
	4 2351 46270	FUSE CLIP	2	C608	C2AQRJ153A--	POLYPR 0.015M 100V	1	
	4 2351 67270	M-CONNECTER FEMALE	2	C609	C1HFRK473A--	MYLAR 0.047M 50V	1	
	4 2351 74570	1P DC JACK-E	1	C610	C1HFRM104A--	MYLAR 0.1M 50V	1	
	4 2361 05570	GT PIN	1	C611	C1HFRK154A--	MYLAR 0.15M 50V	1	
	4 2361 12270	2P MICRO PLUG	1	Δ C612	C2GQRK103A--	POLYPR 0.01M 400V	1	
	4 2361 14670	1P MICRO PLUG	4	Δ	or	C2JQRK103A--	POLYPR 0.01M 630V	1
111 0	9081 02023	2P MICRO SOCKET ASSY	1	Δ C613	C2GQRK153A--	POLYPR 0.015M 400V	1	
111 2	6221 11370	1P TERMINAL	2	Δ C614	C2GQRK223A--	POLYPR 0.022M 400V	1	
Δ F701	4 2341 08770	FUSE 315MA250V SEMKO	1	Δ C615	C2GQRK333A--	POLYPR 0.033M 400V	1	
Δ F702	4 2341 06770	FUSE 2A 250V SEMKO	1	C616	C1ARE-108A--	ELECT 1000M 10V	1	
SG01	4 2341 06270	SPARK GAP	1	C618	C1CRE-477A--	ELECT 470M 16V	1	
or	4 2341 07770	SPARK GAP	1	C619	C1HFRM104A--	MYLAR 0.1M 50V	1	
Δ	111 0 9131 53000	AC CORD ASSY-CEE	1	C620	C1HFRK473A--	MYLAR 0.047M 50V	1	
				C621	C1HAEM009T--	ELECT 4.7M 50V	1	
				C622	C2CRE-105A--	ELECT 1M 160V	1	
				C624	C2HYDP223Z--	CERAMIC 22000PZ 500V	1	
				C625	C2GQRM224A--	POLYPR 0.22M 400V	1	
				C626	C2HYDM101W--	CERAMIC 100P W 500V	1	
				C627	C1HYDK102W--	CERAMIC 1000P W 50V	1	
				Δ C705	C1ERE-228A--	ELECT 2200M 25V	1	

- NOTICE:**
- Parts orders must contain Model Number, Parts Number and Description.
 - Ordering quantity of resistors, capacitors and screws must be multiple of 10pcs.
 - Component parts indicated by parentheses in the column Q'ty are not available.

PARTS LIST

Schematic Location	Parts No.	Description	Q'ty	Schematic Location	Parts No.	Description	Q'ty
△ C706	C1ETDM475A--	TANTAL 4.7M 25V	1	R707	R2ESPJ122A	CARBON 1.2K 1/4WJ	1
△ or	C1ETEM475A--	TANTAL 4.7M 25V	1	R708	R2ESPJ272A	CARBON 2.7K 1/4WJ	1
C707	C1CRE-226A--	ELECT 22M 16V	1	R709	R2ESPJ122A	CARBON 1.2K 1/4WJ	1
FIXED RESISTORS							
R201	R2ESPJ750A	CARBON 75 1/4WJ	1	R901	R2ESPJ152A	CARBON 1.5K 1/4WJ	1
R202	R2ESPJ473A	CARBON 47K 1/4WJ	1	R903	R2ESPJ152A	CARBON 1.5K 1/4WJ	1
R203	R2ESPJ101A	CARBON 100 1/4WJ	1	R904	R2ESPJ333A	CARBON 33K 1/4WJ	1
R204	R2ESPJ333A	CARBON 33K 1/4WJ	1	R905	R2ESPJ223A	CARBON 22K 1/4WJ	1
R205	R2ESPJ821A	CARBON 820 1/4WJ	1	TUBES AND SEMICONDUCTORS			
R206	R2ESPJ271A	CARBON 270 1/4WJ	1	D201	4 2021 10770	SI DIODE ERB24-02D	1
R207	R2ESPJ392A	CARBON 3.9K 1/4WJ	1	or	4 2021 15870	SI DIODE SM-1-02FR	1
R208	R2ESPJ222A	CARBON 2.2K 1/4WJ	1	D601	4 2020 03500	GE DIODE 1S188TV	1
R209	R2ESPJ154A	CARBON 150K 1/4WJ	1	D602	4 2020 03500	GE DIODE 1S188TV	1
R210	R2ESPJ104A	CARBON 100K 1/4WJ	1	△ D603	4 2021 10770	SI DIODE ERB24-02D	1
R211	R2ESPJ223A	CARBON 22K 1/4WJ	1	or	4 2021 15870	SI DIODE SM-1-02FR	1
R212	R2ESPJ270A	CARBON 27 1/4WJ	1	D604	4 2021 09670	SI DIODE 1S1834	1
R213	R3DXPJ222A	OXIDE-M 2.2K 2WJ	1	or	4 2021 21370	SI DI SM-1.5-02FRT	1
R251	R2ESPJ103A	CARBON 10K 1/4WJ	1	D605	4 2021 10770	SI DIODE ERB24-02D	1
R252	R2ESPJ394A	CARBON 390K 1/4WJ	1	or	4 2021 15870	SI DIODE SM-1-02FR	1
R253	R2ESPJ332A	CARBON 3.3K 1/4WJ	1	D606	4 2021 10470	SI DIODE ERB24-06D	1
R254	R2ESPJ151A	CARBON 150 1/4WJ	1	D607	4 2021 10270	SI DIODE ERB24-04D	1
R401	R2ESPJ221A	CARBON 220 1/4WJ	1	or	4 2021 15970	SI DIODE SM-1-04FR	1
R402	R2ESPJ273A	CARBON 27K 1/4WJ	1	D608	4 2021 10470	SI DIODE ERB24-06D	1
R403	R2ESPJ274A	CARBON 270K 1/4WJ	1	△ D701	4 2021 19970	SI DIODE S2VC10R	1
R404	R2ESPJ682A	CARBON 6.8K 1/4WJ	1	△ D702	4 2021 19870	SI DIODE S2VC10	1
△ R405	R2HFPJ100A	F-OXIDE 10 1/2WJ	1	△ D703	4 2021 14870	ZE DIODE WZ-063	1
R501	R2ESPJ123A	CARBON 12K 1/4WJ	1	or	4 2021 16270	ZE DIODE RD6.2E	1
R502	R2ESPJ682A	CARBON 6.8K 1/4WJ	1	D704	4 2021 17770	LED SLP-131B	1
R503	R2ESPJ272A	CARBON 2.7K 1/4WJ	1	IC501	4 2061 08670	IC-UPC1031H2	1
R504	R2ESPJ273A	CARBON 27K 1/4WJ	1	or	4 2061 09970	IC-LA1385	1
R505	R2ESPJ103A	CARBON 10K 1/4WJ	1	Q201	TG2SC536----	SI TR 2SC536	1
R506	R3APPJ0R6A	OXIDE-M 0.6 1WJ	1	or	TN2SC945----	SI TR 2SC945	1
R507	R2ESPJ102A	CARBON 1K 1/4WJ	1	Q202	TG2SC536--E--	SI TR 2SC536	1
R508	R2ESPJ103A	CARBON 10K 1/4WJ	1	Q203	TG2SC2271----	SI TR 2SC2271	1
R509	R2ESPJ472A	CARBON 4.7K 1/4WJ	1	Q251	TG2SC536--F--	SI TR 2SC536	1
R510	R2ESPJ183A	CARBON 18K 1/4WJ	1	Q401	TG2SA608--E--	SI TR 2SA608	1
R511	R2ESPJ274A	CARBON 270K 1/4WJ	1	or	TG2SA608--F--	SI TR 2SA608	1
R512	R2ESPJ103A	CARBON 10K 1/4WJ	1	or	TN2SA733--Q--	SI TR 2SA733	1
R513	R2ESPJ681A	CARBON 680 1/4WJ	1	or	TN2SA733--R--	SI TR 2SA733	1
R514	R2ESPJ394A	CARBON 390K 1/4WJ	1	Q501	TG2SC2271----	SI TR 2SC2271	1
R515	R2ESPJ104A	CARBON 100K 1/4WJ	1	Q601	TG2SC536----	SI TR 2SC536	1
R516	R2ESPJ153A	CARBON 15K 1/4WJ	1	or	TN2SC945----	SI TR 2SC945	1
R517	R2HCPK101A	SOLID 100 1/2WK	1	Q602	TG2SD400----	SI TR 2SD400	1
R601	R2ESPJ391A	CARBON 390 1/4WJ	1	Q603	TG2SD823----	SI TR 2SD823	1
R602	R2ESPJ822A	CARBON 8.2K 1/4WJ	1	or	TN2SC2373----	SI TR 2SC2373	1
R603	R2ESPJ331A	CARBON 330 1/4WJ	1	Q604	TG2SC536----	SI TR 2SC536	1
R604	R2ESPJ331A	CARBON 330 1/4WJ	1	or	TN2SC945----	SI TR 2SC945	1
R605	R2ESPJ223A	CARBON 22K 1/4WJ	1	Q701	TG2SD613----	SI TR 2SD613	1
R606	R2ESPJ562A	CARBON 5.6K 1/4WJ	1	△ Q702	TG2SC536----	SI TR 2SC536	1
R607	R2ESPJ562A	CARBON 5.6K 1/4WJ	1	or	TN2SC945----	SI TR 2SC945	1
R608	R2ESPJ562A	CARBON 5.6K 1/4WJ	1	Q703	TG2SC536--F--	SI TR 2SC536	1
R609	R2ESPJ332A	CARBON 3.3K 1/4WJ	1	or	TN2SC945--P--	SI TR 2SC945	1
R610	R2ESPJ152A	CARBON 1.5K 1/4WJ	1	△ V901	QNM240XB4--N	CRT 240XB4A	1
△ R611	R2HFPJ330A	F-OXIDE 33 1/2WJ	1	△ or	QNM240XB4--S	CRT 240XB4A	1
R612	R2ESPJ123A	CARBON 12K 1/4WJ	1	△ or	QTM240YB4--N	CRT 240YB4	1
R613	R2ESPJ271A	CARBON 270 1/4WJ	1	△ or	QTM240YB4--S	CRT 240YB4	1
R614	R2ESPJ270A	CARBON 27 1/4WJ	1				
R615	R2ESPJ181A	CARBON 180 1/4WJ	1				
R616	R2ESPJ220A	CARBON 22 1/4WJ	1				
R617	R2HCPK391A	SOLID 390 1/2WK	1				
R618	R2HCPK220A	SOLID 22 1/2WK	1				
R619	R2ESPJ152A	CARBON 1.5K 1/4WJ	1				
R620	R2ESPJ272A	CARBON 2.7K 1/4WJ	1				
△ R621	R2HCPK470A	SOLID 47 1/2WK	1				
△ R622	R2HFPJ330A	F-OXIDE 33 1/2WJ	1				
R624	R2HCPK682A	SOLID 6.8K 1/2WK	1				
R625	R2ESPJ153A	CARBON 15K 1/4WJ	1				
R626	R2ESPJ334A	CARBON 330K 1/4WJ	1				
R627	R2ESPJ684A	CARBON 680K 1/4WJ	1				
△ R702	R3RWVJ150A	WIRE-W 15 7WJ	1				
R703	R2ESPJ101A	CARBON 100 1/4WJ	1				
R704	R2ESPJ471A	CARBON 470 1/4WJ	1				
R705	R2ESPJ330A	CARBON 33 1/4WJ	1				
R706	R2ESPJ331A	CARBON 330 1/4WJ	1				

NOTICE: 1. Parts orders must contain Model Number, Parts Number and Description.
 2. Ordering quantity of resistors, capacitors and screws must be multiple of 10pcs.
 3. Component parts indicated by parentheses in the column Q'ty are not available.